

# Multi Switch ATS

**1:1** 16 A



Plug & Play  
installation



## HIGHLIGHTS

- Redundant power supply
- Load protection
- Versatile to use

The Riello UPS Multi Switch ATS is a high availability intelligent switch that provides redundant power to connected equipment with two AC input sources. The Riello UPS Multi Switch ATS supplies power to the connected loads from a primary mains source. If that primary source becomes unavailable, the Riello UPS Multi Switch automatically transfers loads to the secondary source. The transfer time from one source according to the ITI (CBEMA) chart does not impact the operation of the connected equipment as the switching occurs safely between the two input sources regardless of any phase differences. The Riello UPS Multi Switch ATS monitors the current and provides warnings when power consumption draws near the maximum rating which helps prevent downtime to the equipment.

Riello UPS Multi Switch ATS has 8 IEC 10 A and 1 IEC 16 A outlets allowing several devices to be plugged directly into the ATS without the need for an additional PDU. The units have a connectivity slot which allows for LAN connection and remote management through PowerShield<sup>3</sup> software, Web

interface, SNMP, or SSH which makes the Riello UPS Multi Switch ATS an ideal device for the IT manager who needs flexibility and protection of their IT equipment. Multi Switch ATS provides installations with power supply continuity. Its operating principle ensures higher reliability than a single UPS, (with or without its own internal bypass).

### Operating principle

Multi Switch ATS provides direct distribution of eight 10 A IEC outlets or one 16 A IEC outlet in a system with two input powerlines (two mains inputs, or two UPS). Multi Switch ATS is able to connect to either of the two input power lines, whilst simultaneously monitoring the power uptake.

### Protection against load faults

If one of the loads fails (e.g. short circuit), the Multi Switch ATS disconnects the group of sockets where the load is connected, thus preventing other loads from being switched off (i.e. in the event of poor discrimination of the protection devices).

### Protection against power supply faults

If one of the two power sources falls outside tolerance levels, Multi Switch ATS will transfer the load to the second powersource (switching is instantaneous if the two sources are in phase).

Multi Switch ATS units switch power with no impact to IT equipment. Depending on the ITI Curve, typical power supplies will operate

20 ms after AC voltage drops to zero. The IEEE 1100-1999 standard also references the ITI curve. The SSI (Server System Infrastructure) standard recommends a hold-up time for power supplies to be a minimum of 21 ms for a voltage range of 100-240 V. Multi Switch ATS units switch sources under these industry standard times. The switching time includes the time for the built-in intelligence to determine whether the voltage and frequency are in range. Any point of failure in the electronics does not cause a drop out of the output voltage because the unit incorporates redundancy of its electronic circuitry to avoid fault tolerance.

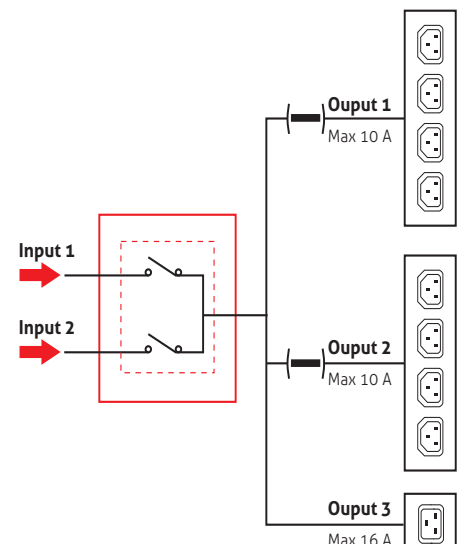

## Features

- Full protection for loads against mains and load failures
- Redundant power supply
- Versatile to use: Multi Switch ATS can be powered with 2 different power supplies (including 2 UPS of different sizes/types)
- 19" cabinet installation
- Display panel
- Can be connected to PowerNetGuard supervision software
- No signal connection between the Multi Switch ATS and the power sources or loads is necessary
- Compatible with PowerShield<sup>3</sup> software
- Slot for communications boards: the optional network card allows for remote in network connectivity, and management through HTTP, SNMP, and SSH protocol.

## DETAILS

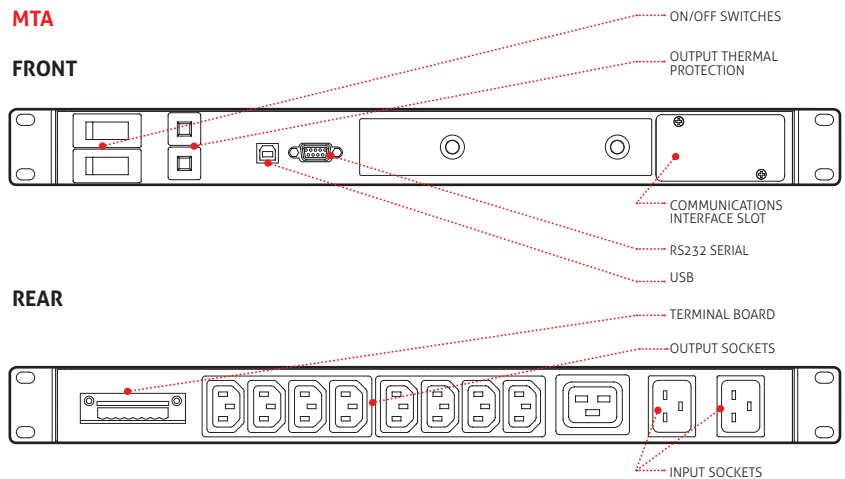

## OPTIONS

### SOFTWARE

PowerShield<sup>3</sup>

### ACCESSORIES

NETMAN 204

MULTICOM 302

MULTICOM 352

MODELS	MTA
<b>NOMINAL CURRENT (A)</b>	<b>16</b>
<b>INPUT</b>	
Nominal voltage - sources S1/S2	230 Vac single-phase + N
Voltage tolerance	180-276 Vac (selectable)
Switched input phases	ph+N (two poles)
Nominal frequency	50/60 Hz
Input sockets	2 IEC 320 (16 A)
<b>OPERATING SPECIFICATIONS</b>	
Transfer type	"Break Before Make" (no overlapping sources)
Transfer time following source failure	< 8 msec (S1/S2 synchronised)    20 msec (S1/S2 non synchronised)
<b>OUTPUT</b>	
Nominal voltage	choice of one of the two input power sources
Max. load for each output	10 A on IEC-320 C13 - 16 A on IEC-320 C19
Output sockets	4+4 IEC-320 C13 (10 A) + 1 IEC-320 C19 (16 A)
<b>ENVIRONMENTAL SPECIFICATIONS</b>	
Efficiency at full load	> 99%
Noise at 1 m from front (from 0 to full load)	< 35 dBA
Storage temperature	-10 °C up to +50 °C
Operating temperature	0 °C - 40 °C
Relative humidity	90% non-condensing
Max. installation height	1000 m at nominal power (-1% power for every 100 m above 1000 m) - Max 4000 m
Reference standard	EN 62310-1 (safety) EN 62310-2 (electro-magnetic compatibility)
<b>INFO FOR INSTALLATION</b>	
Weight (kg)	6
Dimensions (WxDxH) (mm)	19" x 330 x 1U
Colour	RAL 5004
IP rating	IP 20
Communications	RS232 / USB / Slot for communication interface / Relay contacts port

The information in this document is subject to change without notice. Riello UPS assumes no responsibility for any errors that may appear in this document. DATMTA1Y18CEN